

MC-10



IMMERSA MOTOR CONTROL

Features:

- Compatible with Most 3 Phase Brushless DC Motors
- Supports Motor Speed, Direction, and Braking
- 1 x 75V Motor Input
- 1 x 75V Power Supply Output
- Operating Temperature: 0-80°C (32-176°F)

Benefits:

- Durable and reliable
- Simple, inexpensive installation
- Small footprint requires minimal space
- UL Listed
- Fully-encapsulated for maximum environmental protection
- Low power consumption
- Easily upgradeable and scaleable to meet specific needs

Wide Range of Applications:

- Ideal for commercial foodservice equipment such as conveyor ovens, holding cabinets, fryers, refrigeration equipment, dishwashers, combi ovens, industrial machines, and more.

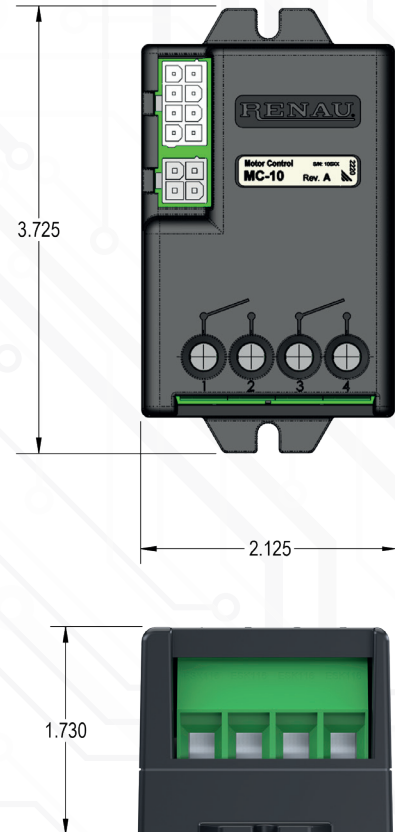

Dimensions:

- 2.125" W x 3.725" H x 1.730" D

Warranty:

- Every Renau product is thoroughly tested at numerous stages of production and comes with an extended three (3) year warranty.



We do more than design. We invent.



9309 Deering Ave. Chatsworth, CA 91311 USA

Tel: 818.341.1994 ext. 349
 Fax: (818) 341-8063
 info@renau.com
 www.renau.com

Specifications are subject to change without notice. The products manufactured by RENAU are protected under one or more of the following U.S. Patents: 6,850,850 6,816,670 6,636,772 6,546,944 6,214,239 5,835,993 4,943,706 4,849,098 and other patents pending. Designed and manufactured in the U.S.A.